

Instructions For Use

JA-25.50 Fixed-Angle Rotor

For Use in Beckman Coulter
J2 and Avanti J Series Centrifuges



PN J-TB-056FB
February 2014



Beckman Coulter, Inc.
250 S. Kraemer Blvd.
Brea, CA 92821 U.S.A.



JA-25.50 Fixed-Angle Rotor

PN J-TB-056FB (February 2014)

Copyright ©1995–2014 Beckman Coulter, Inc.

All rights reserved. No part of this document may be reproduced or transmitted in any form or by any means, electronic, mechanical, photocopying, recording, or otherwise, without prior written permission from Beckman Coulter, Inc.

Avanti, Beckman Coulter, and the stylized logo are trademarks of Beckman Coulter, Inc. and are registered in the USPTO.

All other trademarks, service marks, products, or services are trademarks or registered trademarks of their respective holders.

Find us on the World Wide Web at:

www.beckmancoulter.com

Made in the Ireland
Printed in the U.S.A.

Safety Notice

Read all product manuals and consult with Beckman Coulter-trained personnel before attempting to use this equipment. Do not attempt to perform any procedure before carefully reading all instructions. Always follow product labeling and manufacturer's recommendations. If in doubt as to how to proceed in any situation, contact your Beckman Coulter Representative.

Alerts for Warning, Caution, Important, and Note

WARNING

WARNING indicates a potentially hazardous situation which, if not avoided, could result in death or serious injury.

CAUTION

CAUTION indicates a potentially hazardous situation, which, if not avoided, may result in minor or moderate injury. It may also be used to alert against unsafe practices.

IMPORTANT IMPORTANT is used for comments that add value to the step or procedure being performed. Following the advice in the Important adds benefit to the performance of a piece of equipment or to a process.

NOTE NOTE is used to call attention to notable information that should be followed during installation, use, or servicing of this equipment.

Safety Information for the JA-25.50 Rotor

This rotor was developed, manufactured, and tested for safety and reliability as part of a Beckman Coulter centrifuge/rotor system. Its safety or reliability cannot be assured if used in a centrifuge not of Beckman Coulter's manufacture or in a Beckman Coulter centrifuge that has been modified without Beckman Coulter's approval.

Handle body fluids with care because they can transmit disease. No known test offers complete assurance that such fluids are free of micro-organisms. Some of the most virulent—Hepatitis (B and C) viruses, HIV (I–V), atypical mycobacteria, and certain systemic fungi—further emphasize the need for aerosol protection. Handle other infectious samples according to good laboratory procedures and methods to prevent spread of disease. Because spills may generate aerosols, observe proper safety precautions for aerosol containment. Do not run toxic, pathogenic, or radioactive materials in this rotor without taking appropriate safety precautions. Biosafe containment should be used when Risk Group II materials (as identified in the World Health Organization **Laboratory Biosafety Manual**) are handled; materials of a higher group require more than one level of protection.

Safety Notice

Safety Information for the JA-25.50 Rotor

The rotor and accessories are not designed for use with materials capable of developing flammable or explosive vapors. Do not centrifuge such materials in nor handle or store them near the centrifuge.

Although rotor components and accessories made by other manufacturers may fit in the JA-25.50 rotor, their safety in this rotor cannot be ascertained by Beckman Coulter. Use of other manufacturers' components or accessories in the JA-25.50 rotor may void the rotor warranty and should be prohibited by your laboratory safety officer. Only the components and accessories listed in this publication should be used in this rotor.

Do not run an empty rotor. Place filled tubes in at least two opposing cavities. Make sure that filled containers are loaded symmetrically into the rotor and that opposing tubes are filled to the same level with liquid of the same density.

If disassembly reveals evidence of leakage, you should assume that some fluid escaped the rotor. Apply appropriate decontamination procedures to the centrifuge and accessories.

Never exceed the maximum rated speed of the rotor and labware in use. Refer to the section on [Run Speeds](#), and derate the run speed as appropriate.

Do not use sharp tools on the rotor that could cause scratches in the rotor surface. Corrosion begins in scratches and may open fissures in the rotor with continued use.

Contents



Safety Notice, iii

Alerts for Warning, Caution, Important, and Note, iii

Safety Information for the JA-25.50 Rotor, iii

JA-25.50 Fixed-Angle Rotor, 1

Specifications, 1

Description, 2

Preparation and Use, 4

Care and Maintenance, 14

Returning a Rotor, 18

Supply List, 19

Beckman Coulter, Inc. J Series Rotor Warranty

Related Documents

Illustrations

- 1 The JA-25.50 Fixed-Angle Rotor, 3
- 2 Fluid-Containment Annulus and Finger-Grip Grooves, 4
- 3 Typical Examples of Arranging Tubes in the Rotor, 5

Tables

- 1 Temperature Compensation Settings for Analog- and Microprocessor-Controlled Centrifuges , 8
- 2 Temperature Compensation Settings for the Model J2-HC Analog Centrifuge. , 8
- 3 Available Tubes and Bottles for the JA-25.50 Rotor, 12
- 4 Relative Centrifugal Fields for the JA-25.50 Rotor, 15

JA-25.50 Fixed-Angle Rotor

Specifications

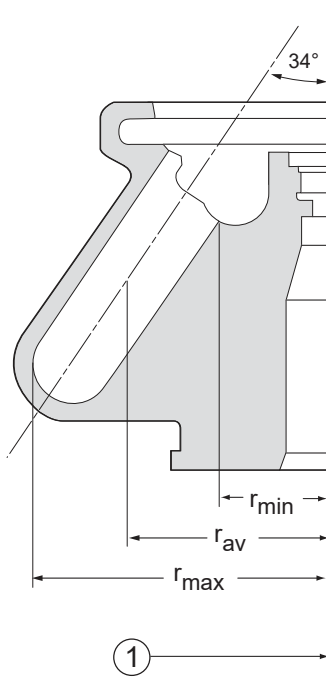

1. Axis of Rotation

Maximum speed.....	25,000 RPM ^a
Critical speed range ^b	600 to 800 RPM
Density rating at maximum speed.....	1.2 g/mL
Maximum allowable imbalance of opposing loads.....	2 grams
Relative Centrifugal Field ^c at maximum speed	
At r_{\max} (108 mm).....	75,600
At r_{av} (73.2 mm).....	51,200
At r_{\min} (38.5 mm).....	27,000
k factor at maximum speed.....	418
Conditions requiring speed reductions.....	see Run Speeds
Number of tube cavities (round bottom).....	8
Available bottles and tubes.....	see Table 3
Nominal tube dimensions.....	29 04 mm
Nominal tube capacity.....	50 mL
Nominal rotor capacity.....	400 mL
Approximate acceleration time to maximum speed (rotor fully loaded)	
in an Avanti J centrifuge (to 25,000 RPM).....	3 1/2 min
in a J2 series centrifuge (to 21,000 RPM).....	1 3/4 min
Approximate deceleration time from maximum speed (rotor fully loaded, max. brake)	
in an Avanti J centrifuge (from 25,000 RPM).....	1 3/4 min
in a J2 series centrifuge (from 21,000 RPM).....	2 1/2 min
Rotor weight, empty.....	8.1 kg (17.8 lb)
Rotor weight, maximum sample mass.....	8.7 kg (19.1 lb)
Rotor material.....	aluminum
Rotor entry code for microprocessor-controlled J2 series instruments.....	25.5

JA-25.50 Fixed-Angle Rotor

Description

- Discontinued Avanti J-25I and Avanti J-25, 50-Hz models: at 4°C (at 24°C ambient) – 24,000 RPM (69,700 $\times g$) at 7°C (at 24°C ambient) – 25,000 RPM (75,600 $\times g$). In Avanti JXN-26, J-26S XP series, J-26 XP series, and discontinued J-20 XP series, at speeds above 20,000, the minimum temperature set point will be above 4°C. NOTE: at ambient temperatures above 24°C, the temperatures listed above may not be achievable.
- The critical speed range is the range of speeds over which the rotor shifts so as to rotate about its center of mass. Passing through the critical speed range is characterized by some vibration.
- Relative Centrifugal Field (RCF) is the ratio of the centrifugal acceleration at a specified radius and speed ($r\omega^2$) to the standard acceleration of gravity (g) according to the following formula: $RCF = \frac{r\omega^2}{g}$ — where r is the radius in millimeters, ω is the angular velocity in radians per second ($2\pi \text{ RPM} / 60$), and g is the standard acceleration of gravity (9807 mm/s²). After substitution: $RCF = 1.12r (\text{RPM}/1000)^2$

Description

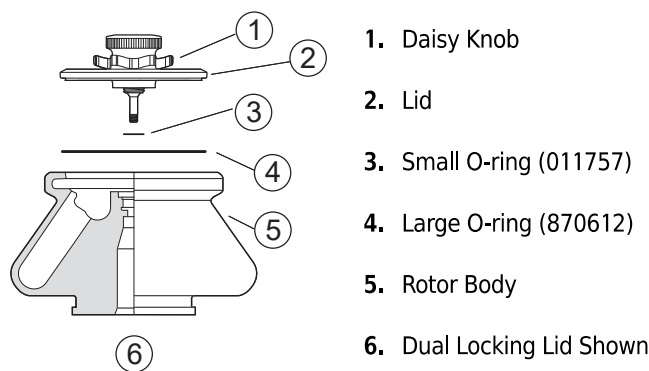

Beckman Coulter JA-25.50 rotors are manufactured in a facility that maintains certifications to both ISO 9001:2008 and ISO 13485:2003. They are for use with the specified Beckman Coulter centrifuges.

The JA-25.50 fixed-angle rotor is designed to hold up to eight 50-mL tubes at a 34-degree angle (see [Figure 1](#)). Used in Beckman Coulter Avanti J and J2 series centrifuges, the JA-25.50 rotor develops centrifugal forces that can efficiently pellet cells from large volumes, or cell particles from tissue homogenates. Short column methods (i.e., partially filled tubes) may also be used to purify large quantities of virus in a cushion gradient.

Figure 1 The JA-25.50 Fixed-Angle Rotor*

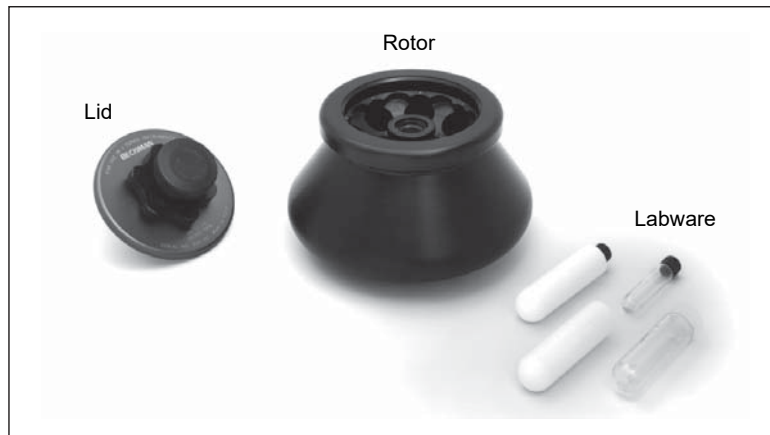

The dual-locking lid assembly allows the rotor to be loaded into and removed from the centrifuge with the lid attached. The rotor may be placed under a safety hood before the lid is attached or removed. The rotor is also available with a single-locking lid assembly. The rotor has been tested[†] with both lid configurations to demonstrate containment of microbiological aerosols under normal conditions of the associated Beckman Coulter centrifuge when used and maintained as instructed.

The JA-25.50 rotor has a patented fluid-containment annulus, located below the O-ring sealing surface (see [Figure 2](#)). If tubes are overfilled or if leakage occurs during centrifugation, the annulus holds enough volume that all of the liquid is kept inside the rotor — even if all eight tubes leak at the same time. This feature virtually eliminates the escape of liquid into the centrifuge chamber. Finger-grip grooves in the area around and between each tube cavity (see [Figure 2](#)) provide extra room for fingers as tubes are loaded and unloaded.

The rotor and lid are made of anodized aluminum. Two O-rings made of Buna N rubber, both located in the rotor lid, help to maintain atmospheric pressure inside the rotor during centrifugation when they are properly lubricated. Vertical pins in the rotor drive hole mate with the centrifuge drive hub to prevent the rotor from slipping during acceleration and deceleration.

See the Warranty at the back of this manual for warranty information.

* The dual-locking lid is shown.

† Validation of microbiological containment was done at an independent third-party testing facility (CAMR, Porton Down, UK, or USAMRIID, Ft. Detrick, MD, U.S.A.). Improper use or maintenance may affect seal integrity and thus containment.

Figure 2 Fluid-Containment Annulus and Finger-Grip Grooves

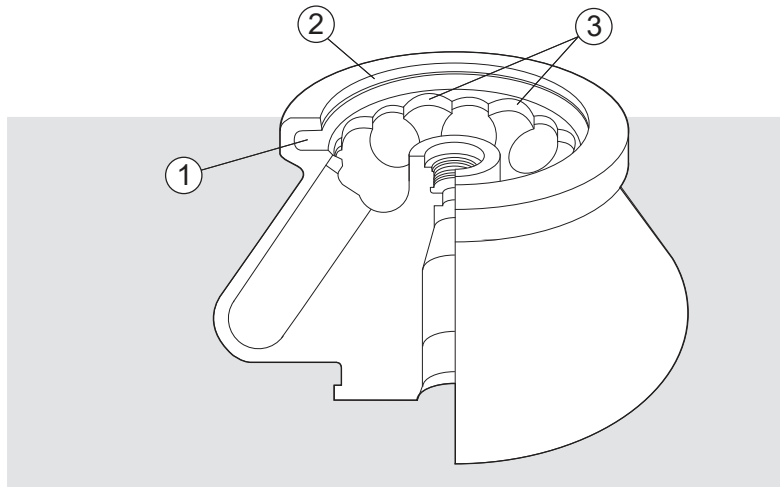

1. Fluid Containment Annulus
2. O-ring Sealing Surface
3. Finger-Grip Grooves

Preparation and Use

Specific information about the JA-25.50 rotor is given here. Use the Rotors and Tubes for Beckman Coulter J Series Centrifuges manual (publication JR-1M) and the centrifuge instruction manual along with this manual for complete rotor and accessory operation.

NOTE Although rotor components and accessories made by other manufacturers may fit in the JA-25.50 rotor, their safety in this rotor cannot be ascertained by Beckman Coulter. Use of other manufacturers' components or accessories in the JA-25.50 rotor may void the rotor warranty and should be prohibited by your laboratory safety officer. Only the components and accessories listed in this publication should be used in this rotor.

Prerun Safety Checks

Read the [Safety Notices](#) section at the front of this manual before using the rotor.

- 1 Make sure that the rotor, lid, and all tubes or bottles and accessories are clean and show no signs of corrosion or cracking.
- 2 Verify that the bottles or tubes being used are listed in [Table 3](#).
- 3 Refer to [Chemical Resistances](#) (publication IN-175), included in the [Rotors and Tubes](#) CDs for the chemical compatibilities of all materials used.

Rotor Preparation

For runs at other than room temperature refrigerate or warm the rotor beforehand for fast equilibration.

- 1 Be sure that metal threads in the rotor are clean and lightly but evenly lubricated with Spinkote lubricant (306812).
Also ensure that O-rings are lightly but evenly coated with silicone vacuum grease (335148).
- 2 Load the filled containers symmetrically into the rotor.
 - (Refer to [Tubes and Bottles](#) on page 11 for information about containers.)
 - If fewer than eight tubes are being run they must be arranged symmetrically in the rotor (see [Figure 3](#)).
 - Opposing tubes must be filled to the same level with liquid of the same density.

Figure 3 Typical Examples of Arranging Tubes in the Rotor

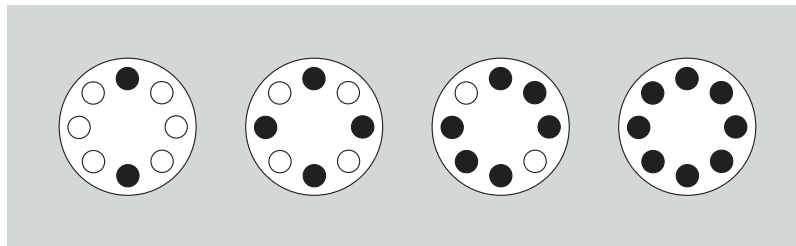

NOTE Two, four, six, or eight tubes can be centrifuged per run if they are arranged in the rotor as shown.

NOTE Do not run an empty rotor. Place filled tubes in at least two opposing cavities.

Operation

- 1 Precool the rotor in the centrifuge or in a refrigerator before use—especially before short runs—to ensure that the rotor reaches the set temperature.
A suggested precooling cycle is a minimum of 30 minutes at 2000 RPM at the required temperature.
- 2 If fluid containment is required, use capped tubes or bottles.
It is strongly recommended that all containers carrying physiological fluids be capped to prevent leakage.
- 3 If you are using an Avanti J series centrifuge, select the JA-25.50 rotor.

-
- 4 If you are using a microprocessor-controlled J2 series centrifuge, enter rotor code **25.5**. Refer to your centrifuge instruction manual for additional information.
-
- 5 For additional operating information, see the following:
 - [Run Times](#), page 13, for using k factors to adjust run durations.
 - [Run Speeds](#), page 14, for information about speed limitations.
-

Installing the Rotor

-
- 1 To prevent the rotor from sticking to the centrifuge drive hub, apply a thin coat of Spinkote lubricant to the rotor drive pins and to the lid knob threads
-
- 2 Lightly coat the large and small lid O-rings with silicone vacuum grease.
-
- 3 **Dual-locking lid only.** Place filled tubes into the rotor, then place the lid on the rotor and turn the daisy knob to the right (clockwise) until secure.
Do not overtighten.
-
- 4 Carefully lower the rotor straight down onto the centrifuge drive spindle hub.
Do not drop the rotor onto the spindle hub.
-
- 5 Slowly turn the rotor around the drive spindle to make sure that it is properly seated.
-
- 6 Secure the rotor to the centrifuge drive spindle as follows:
 - a. **Dual-locking lid:** press the lid knob down and turn it to the right (clockwise) until secure, no more than two full turns.
Do not overtighten

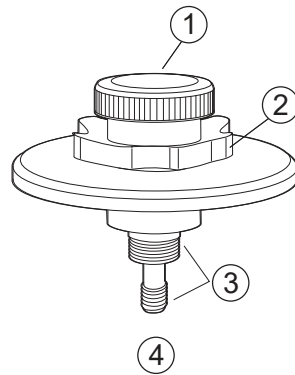

1. Tie-down Knob
2. Daisy Knob
3. Lubricate Threads
4. Dual-Locking Lid

- b. **Single-locking lid:** place filled tubes into the rotor, then place the lid on the rotor. Press the lid knob down and turn it to the right (clockwise) until secure. Do not overtighten.

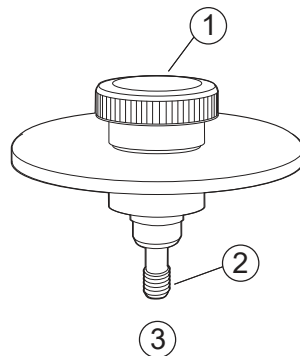

1. Tie-down Knob
2. Lubricate Threads
3. Single-Locking Lid

⚠ CAUTION

If the rotor is left in the centrifuge between runs, make sure that the rotor is seated on the drive hub and that the tie-down knob is tight before each run.

Temperature

To ensure that the JA-25.50 rotor reaches the required temperature during the run, follow the appropriate instructions below for the model of J centrifuge being used.

Avanti J Series Centrifuges

Enter the run temperature according to the instructions in your centrifuge instruction manual. No additional input is required.

J2 Series Centrifuges

Enter the required run temperature **and** the appropriate temperature compensation units (see [Table 1](#) and [Table 2](#)) on the centrifuge control panel as follows.

Table 1 Temperature Compensation Settings for Analog- and Microprocessor-Controlled Centrifuges ^a

Rotor Speed (RPM)	Required Sample Temperature (°C)						
	-20	-10	2	5	10	20	40
21,000	N ^b	N	-7	-5	-6	-5	-9
18,000	N	-5	-5	-5	-5	-4	-7
15,000	0	-2	-3	-3	-2	-2	-6
10,000	0	0	-1	0	-1	0	-3

a. (Models J2-HS, J2-MI, and J2-MC). Interpolate if intermediate values are required.

b. An "N" indicates that the rotor cannot achieve the required temperature at this speed.

Table 2 Temperature Compensation Settings for the Model J2-HC Analog Centrifuge. ^a

Rotor Speed (RPM)	Required Sample Temperature (°C)						
	-20	-10	2	5	10	20	40
18,000	N ^b	-8	-6	-6	-6	-6	-5
15,000	-7	-6	-5	-5	-5	-4	-4
10,000	-5	-3	-2	-3	-4	-3	-2

a. Interpolate if intermediate values are required

b. An "N" indicates that the rotor cannot achieve the required temperature at this speed.

Analog J2 Series Centrifuges (Models J2-HS and J2-HC)

- 1 Turn the **SET** knob on the centrifuge control panel to the required sample temperature.
- 2 Find the compensation value in [Table 1](#) for Models J2-HS or [Table 2](#) for Model J2-HC that corresponds to the required temperature and run speed.
Set the **COMP** dial to that setting.
(Interpolate if intermediate values are required.)

NOTE Temperature settings for J-21 and J2-21 series centrifuges must be empirically determined.

Microprocessor-Controlled J Series Centrifuges (Models J-MI and J-MC)

- 1** Press the **TEMP** key on the centrifuge control panel and then use the keypad to enter the sample temperature.

 - 2** Find the compensation value in [Table 1](#) that corresponds with the set temperature and run speed.

 - 3** Press **COMP ADJ**.
The word “**COMP**” flashes below the TEMPERATURE display and the display flashes.

 - 4** Use the keypad to enter the required compensation value.
Press the  key to enter a minus sign; pressing it again will remove the minus sign.

 - 5** Check the temperature display. (If the entry is incorrect, press **ce** and reenter the digits.)

 - 6** When the entry is correct, press **ENTER/RECALL**.
-

NOTE To clear a COMP ADJ entry, press **COMP ADJ, 0,** and **ENTER/RECALL**.

Run Procedure

When the rotor is properly loaded and installed in the centrifuge, you are ready to perform the run. Refer to the applicable centrifuge instruction manual for operating instructions.

⚠ WARNING

Operator error or tube failure may generate aerosols. Toxic, pathogenic, or other hazardous materials must not be run in this rotor unless all appropriate safety precautions are taken. Also see the Safety Notice at the beginning of this manual.

⚠ CAUTION

Make sure that the rotor is properly seated on and securely fastened to the drive hub before each run.

Removal and Sample Recovery

⚠ CAUTION

If disassembly reveals evidence of leakage, you should assume that some fluid escaped the rotor. Apply all appropriate safety and decontamination procedures to the centrifuge and accessories.

Dual-Locking Lid

- 1 Place one hand on the rotor to keep it from turning.
Grasp the round lid knob with your other hand and turn the knob to the left (counterclockwise) until the stem disengages from the drive hub threads.

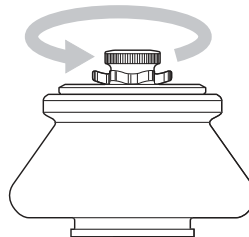

- 2 Hold the knob or place your hands on the rotor and lift the rotor straight up off the drive hub.
- 3 Place the rotor on a counter or bench top under a safety hood.
- 4 Grasp the daisy knob and turn it to the left (counterclockwise) until it disengages.
- 5 Remove the lid and set it aside.

Single-Locking Lid

- 1 Unscrew the lid knob.

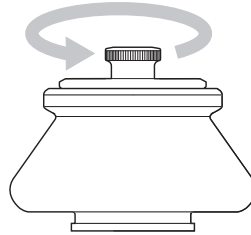

- 2 Remove the lid and set it aside.
- 3 Lift the rotor straight up off the drive hub to avoid bending or damaging the hub.

Tubes and Bottles

The JA-25.50 rotor uses the tubes and bottles listed in [Table 3](#). Be sure to use only those items listed, and to observe the maximum speed limits and fill volumes shown. (Maximum fill volume is the maximum amount that can be centrifuged in the container listed.)

Refer to **Chemical Resistances** (publication IN-175) for information on the chemical compatibilities of tube and accessory materials.

Temperature Limits

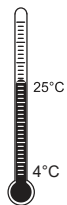

- Plastic tubes and bottles have been centrifuge tested for use at temperatures between 4 and 25°C. For centrifugation at other temperatures, pretest tubes under anticipated run conditions.
- If plastic containers are frozen before use, make sure that they are thawed to at least 4°C prior to centrifugation.

Thickwall Tubes



Thickwall polypropylene, and polycarbonate tubes can be run partially filled (at least half filled) with or without caps, but all opposing tubes for a run must be filled to the same level with liquid of the same density. Do not overfill capless tubes..

Table 3 Available Tubes and Bottles for the JA-25.50 Rotor^a





















Tube or Bottle			Required Accessory		Part Number	Max Speed ^{b/} RCF/ k factor
Dimensions and Volume	Description	Part Number	Max. Fill Volume (mL)	Description		
24  104 mm 50 mL	polycarbonate bottle assy w/cap	361693	40	none	—	25,000 RPM 75,600  418
29  104 mm 50 mL	polypropylene bottle assy w/cap	361694	40	none	—	25,000 RPM 75,600  418
29  104 mm 50 mL	polycarbonate bottle, screw-cap	357002	40	none	—	25,000 RPM 75,600  418
29  104 mm 50 mL	polypropylene bottle, screw-cap	357003	40	none	—	25,000 RPM 75,600  418
29  104 mm 50 mL	polycarbonate thickwall tube, snap-on cap	363664	36.5	natural 29-mm cap red 29-mm cap green 29-mm cap yellow 29-mm cap blue 29-mm cap	356264 ^c 357359 ^c 357360 ^c 357361 ^c 357362 ^c	25,000 RPM 75,600  418
9  104 mm 50 mL	polypropylene thickwall tube, ^d snap-on cap	357005	36.5	natural 29-mm cap red 29-mm cap green 29-mm cap yellow 29-mm cap blue 29-mm cap	356264 ^c 357359 ^c 357360 ^c 357361 ^c 357362 ^c	25,000 RPM 75,600  418
29  104 mm 50 mL	polycarbonate thickwall tube, no cap	363647	35	none	—	25,000 RPM 75,600  418
29  104 mm 50 mL	polypropylene thickwall tube, no cap	357007	35	none	—	25,000 RPM 75,600  418
16  80 mm 10 mL	polycarbonate bottle, screw-cap	355672	10	adapter	361703 ^e	25,000 RPM 63,240  350
9.5  38 mm 1.5 mL	polypropylene tube	357448	1.3	adapter	361705 ^e	25,000 RPM 50,960  182

Table 3 Available Tubes and Bottles for the JA-25.50 Rotor^a (Continued)

Tube or Bottle			Required Accessory		Part Number	Max Speed ^b / RCF/ k factor
Dimensions and Volume	Description	Part Number	Max. Fill Volume (mL)	Description		
9.5 × 38 mm 1.5 mL	polypropylene tube	356090	1.3	adapter	361705 ^c	25,000 RPM 50,960 $\times g$ 182
25 × 105 mm	glass tube ^f	f	f	adapter	870331	f

- Use only the items listed here and observe fill volumes and maximum run speeds.
- Maximum speeds listed are guidelines only. These speeds have been achieved in reliability tests at Beckman Coulter, but because of manufacturing variances no guarantee of performance or fit is expressed or implied.
- Polypropylene, package of 25.
- Above 20°C fill polypropylene tubes at least half full. Containers may be filled less than or equal to the maximum fill volumes provided in this table.
- Polyetherimide (PEI); package of 2.
- Commercially available. Observe manufacturer’s speed and fill volume guidelines.



Polycarbonate and Polypropylene Bottles

Capped polycarbonate and polypropylene bottles may be centrifuged completely filled, or partially filled (not less than half full). Containers placed in opposing positions in the rotor must be filled to the same level..

Run Times

To pellet particles of known sedimentation coefficient s , calculate the run time t using the k factor (395) of the rotor.* Time is in hours and s is in Svedberg units.

$$t = \frac{k}{s} \left(\frac{25\,000}{\text{actual run speed}} \right)^2 \quad \text{EQ 1}$$

For example, at 25,000 RPM, mammalian viruses ($s = 700 \text{ S}$) can be pelleted in

$$t = \frac{395}{700} \left(\frac{25\,000}{25\,000} \right)^2 \approx 30 \text{ minutes.} \quad \text{EQ 2}$$

* Based on sedimentation in water at 20°C. Assumes full tubes.

Run Speeds

The centrifugal force at a given radius in a rotor is a function of run speed. Comparisons of forces between different rotors are made by comparing the rotors' relative centrifugal fields (RCF). When rotational speed is selected so that identical samples are subjected to the same RCF in two different rotors, the samples are subjected to the same force (see [Table 4](#)).

Do not select rotational speeds higher than the maximums you have determined to be appropriate for your protocols (in no case above 25,000 RPM). When solutions more dense than 1.2 g/mL are centrifuged in this rotor, use [EQ 3](#) to calculate the reduced maximum allowable rotor speed.

$$\text{reduced maximum speed} = (25,000 \text{ RPM}) \sqrt{\frac{1.2 \text{ g/mL}}{\text{density of tube contents}}} \quad \text{EQ 3}$$

Care and Maintenance

Maintenance

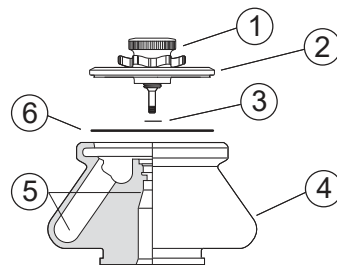

1. Daisy Knob
2. Lid
3. Small O-ring (011757)
4. Rotor Body
5. Check for Corrosion
6. Large O-ring (870612)

NOTE Do not use sharp tools on the rotor that could cause scratches in the rotor surface. Corrosion begins in scratches and may open fissures in the rotor with continued use.

- 1 Periodically (at least monthly) inspect the rotor, especially inside cavities, for rough spots or pitting, white powder deposits (frequently aluminum oxide), or heavy discoloration. If any of these signs are evident, do not run the rotor. Contact your Beckman Coulter representative for information about the Field Rotor Inspection Program and the rotor repair center.
- 2 Before using the rotor, inspect the rotor drive pins to ensure that they are not damaged. Damaged drive pins can prevent the rotor from seating properly on the centrifuge drive hub (Avanti J series centrifuges only). To inspect the drive pins, turn the rotor upside down and look into the drive hole in the center of the rotor. If the drive pins appear damaged, contact Beckman Coulter Field Service.*

* In the United States call 1-800-742-3485; outside the U.S. contact your local Beckman Coulter office or visit us on the web at www.beckmancoulter.com

Table 4 Relative Centrifugal Fields for the JA-25.50 Rotor^a

Rotor Speed (RPM)	Relative Centrifugal Field (xg)		
	At r _{max} (108 mm)	At r _{av} (73.2mm)	At r _{min} (38.5 mm)
25,000	75,600	51,200	27,000
23,000	64,000	43,400	22,800
21,000	53,300	36,200	19,000
19,000	43,700	29,600	15,600
17,000	35,000	23,700	12,500
15,000	27,200	18,500	9700
13,000	20,400	13,900	7300
11,000	14,600	9900	5700
9000	9800	6640	3490
7000	5930	4020	2110
5000	3020	2050	1080
3000	1090	737	388
1000	121	82	43

a. Entries in this table are calculated from the formula $RCF = 1.12r (RPM/1000)^2$ and then rounded to three significant digits.

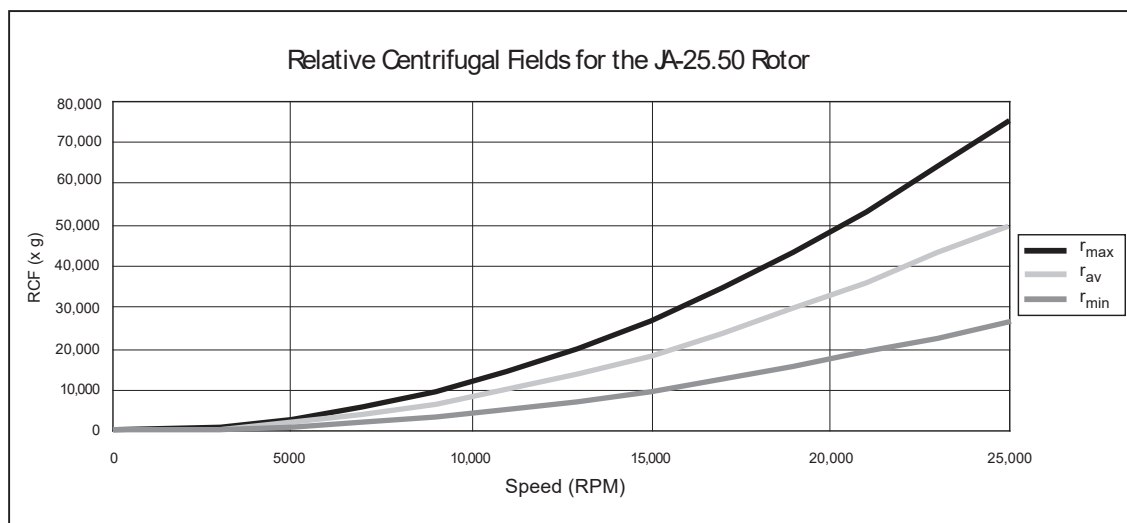

- 3 Regularly lubricate the metal threads in the rotor with a thin, even coat of Spinkote lubricant. Failure to keep these threads lubricated can result in damaged threads.
- 4 Regularly apply silicone vacuum grease to the O-rings. Replace O-rings about twice a year or whenever worn or damaged.
- 5 Refer to **Chemical Resistances** (publication IN-175) for the chemical compatibilities of rotor and accessory materials. Your Beckman Coulter representative provides contact with the Field Rotor Inspection Program and the rotor repair center.

Cleaning

Wash the rotor and rotor components immediately if salts or other corrosive materials are used or if spillage has occurred. Do not allow corrosive materials to dry on the rotor.

Under normal use, wash the rotor frequently (at least weekly) to prevent buildup of residues.

- 1 Remove the O-rings before washing.
- 2 Wash the rotor and lid in a mild detergent, such as Solution 555 (339555), that won't damage the rotor.



Dilute the detergent with water (10 parts water to 1 part detergent).

The Rotor Cleaning Kit contains two plastic-coated brushes and two quarts of Solution 555 (339555) for use with rotors and accessories.

NOTE Do not wash rotor components in a dishwasher. Do not soak in detergent solution for long periods, such as overnight.

- 3 Thoroughly rinse the cleaned rotor and components with distilled water.
- 4 Air-dry the rotor and lid upside down. Do not use acetone to dry the rotor.

- 5 Apply a thin, even coat of silicone vacuum grease to both lid O-rings before replacing them in the lid.

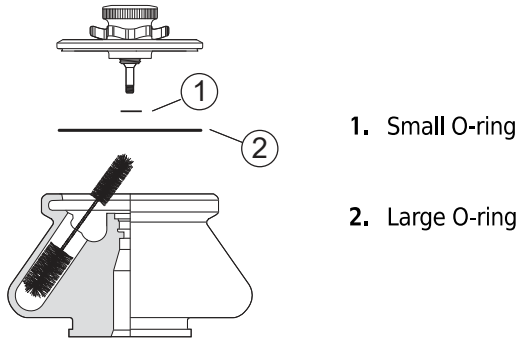

- 6 Clean metal threads every 6 months, or as necessary.
Use a brush and concentrated Solution 555.
Rinse and dry thoroughly, then lubricate lightly but evenly with Spinkote to coat all threads.
- 7 Periodically remove the O-rings and wipe clean as necessary.
- Clean the O-ring grooves with a cotton-tipped swab.
 - Reapply a light film of silicone vacuum grease.

Decontamination



If the rotor (and/or accessories) becomes contaminated with radioactive material, it should be decontaminated using a solution that will not damage the anodized surfaces. Beckman Coulter has tested a number of solutions and found two that do not harm anodized aluminum: RadCon Surface Spray or IsoClean Solution (for soaking),* and Radiacwash.†

NOTE IsoClean can cause fading of colored anodized surfaces. Use it only when necessary and remove it promptly from surfaces.

* In U.S., contact Nuclear Associates (New York); in Eastern Europe and Commonwealth States, contact Victoreen GmbH (Munich); in South Pacific, contact Gammasonics Pty. Ltd. (Australia); in Japan, contact Toyo Medic Co. Ltd. (Tokyo).

† In U.S., contact Biodex Medical Systems (Shirley, New York); internationally, contact the U.S. office to find the dealer closest to you.

While Beckman Coulter has tested these methods and found that they do not damage components, no guarantee of decontamination is expressed or implied. Consult your laboratory safety officer regarding the proper decontamination methods to use.

If the rotor or other components are contaminated with toxic or pathogenic materials, follow appropriate decontamination procedures as outlined by your laboratory safety officer.

Sterilization and Disinfection

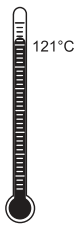

- The rotor and all rotor components can be autoclaved at 121°C for up to an hour. Remove the lid from the rotor and place the rotor, lid, and spacers in the autoclave upside down.
- Ethanol (70%) or hydrogen peroxide (6%) may be used on all rotor components, including those made of plastic. Bleach (sodium hypochlorite) may be used, but may cause discoloration of anodized surfaces. Use the minimum immersion time for each solution, per laboratory standards.



Ethanol is a flammability hazard. Do not use it in or near operating centrifuges.

While Beckman Coulter has tested these methods and found that they do not damage the rotor or components, no guarantee of sterility or disinfection is expressed or implied. When sterilization or disinfection is a concern, consult your laboratory safety officer regarding proper methods to use.

Refer to publication IN-192 (included with each box of tubes) for tube sterilization and disinfection procedures.

Storage

When it is not in use, store the rotor in a dry environment (not in the instrument) with the lid removed to allow air circulation so moisture will not collect in the tube cavities.

Returning a Rotor

Before returning a rotor or accessory for any reason, prior permission must be obtained from Beckman Coulter, Inc. A return form may be obtained from your local Beckman Coulter sales office. The form should contain the following information:

- rotor type and serial number,
- history of use (approximate frequency of use),
- reason for the return,
- original purchase order number, billing number, and shipping number, if possible,
- name and email address of the person to be notified upon receipt of the rotor or accessory at the factory,
- name and email address of the person to be notified about repair costs, etc.

To protect our personnel, it is the customer's responsibility to ensure that all parts are free from pathogens and/or radioactivity. Sterilization and decontamination must be done before returning the parts. Smaller items (such as tubes, bottles, etc.) should be enclosed in a sealed plastic bag.

All parts must be accompanied by a note, plainly visible on the outside of the box or bag, stating that they are safe to handle and that they are not contaminated with pathogens or radioactivity. Failure to attach this notification will result in return or disposal of the items without review of the reported problem.

Use the address label printed on the return form when mailing the rotor and/or accessories.

Customers located outside the United States should contact their local Beckman Coulter office.

Supply List

NOTE Publications referenced in this manual can be obtained at www.beckmancoulter.com, by calling Beckman Coulter at 1-800-742-2345 in the United States, or by contacting your local Beckman Coulter office.

See the **High Performance, High Speed, High Capacity Rotors, Tubes & Accessories** catalog (BR-8102) for detailed information on ordering parts and supplies. For your convenience, a partial list is given below.

Replacement Rotor Parts

Description	Part Number
Rotor assembly, dual-locking lid	363058
Rotor assembly, single-locking lid	363055
Large O-ring for lid	870612
Small O-ring for lid	011757
Lid assembly, dual locking	363023
Lid assembly, single locking	363053

Supplies

NOTE For MSDS information, go to the Beckman Coulter website at www.beckmancoulter.com.

Description	Part Number
Tubes, bottles, and adapters	see Table 3
Rotor Cleaning Kit	339558
Silicone vacuum grease (1 oz)	335148

JA-25.50 Fixed-Angle Rotor
Supply List

Description	Part Number
Solution 555 (1 qt)	339555
Spinkote lubricant (2 oz)	306812

Beckman Coulter, Inc. J Series Rotor Warranty

Subject to the conditions specified below and the warranty clause of the Beckman Coulter, Inc., terms and conditions of sale in effect at the time of sale, Beckman Coulter, Inc. agrees to correct either by repair, or, at its election, by replacement, any defects of material or workmanship which develop within seven (7) years after delivery of a J series rotor to the original buyer by Beckman Coulter, Inc. or by an authorized representative, provided that investigation and factory inspection by Beckman Coulter, Inc. discloses that such defect developed under normal and proper use. Should a Beckman Coulter centrifuge be damaged due to a failure of a rotor covered by this warranty, Beckman Coulter will supply free of charge all centrifuge parts required for repair.

Replacement

Any product claimed to be defective must, if requested by Beckman Coulter, Inc., be returned to the factory, transportation charges prepaid, and will be returned to Buyer with the transportation charges collect unless the product is found to be defective, in which case Beckman Coulter, Inc. will pay all transportation charges.

A defective rotor will be replaced by Beckman Coulter, Inc. at its then current list price less a credit based upon the age of the rotor (years since date of purchase). The Buyer shall not receive credit until the claimed defective rotor is returned to Beckman Coulter's Indianapolis, Indiana facility or delivered to a Beckman Field Service representative.

The replacement price (cost to Buyer) for the respective rotor shall be calculated as follows:

$$\text{Replacement price} = \text{Current rotor list price} \times \frac{\text{years}}{7}$$

Conditions

1. Except as otherwise specifically provided herein, this warranty covers the rotor only and Beckman Coulter, Inc. shall not be liable for damage to accessories or ancillary supplies including but not limited to (i) tubes, (ii) tube caps, (iii) tube adapters, or (iv) tube contents.
2. This warranty is void if the rotor has been subjected to customer misuse such as operation or maintenance contrary to the instructions in the Beckman Coulter rotor or centrifuge manual.
3. This warranty is void if the rotor is operated with a rotor drive unit or in a centrifuge unmatched to the rotor characteristics, or is operated in a Beckman Coulter centrifuge that has been improperly disassembled, repaired, or modified.

Disclaimer

IT IS EXPRESSLY AGREED THAT THE ABOVE WARRANTY SHALL BE IN LIEU OF ALL WARRANTIES OF FITNESS AND OF THE WARRANTY OF MERCHANTABILITY AND THAT BECKMAN COULTER, INC. SHALL HAVE NO LIABILITY FOR SPECIAL OR CONSEQUENTIAL DAMAGES OF ANY KIND WHATSOEVER ARISING OUT OF THE MANUFACTURE, USE, SALE, HANDLING, REPAIR, MAINTENANCE, OR REPLACEMENT OF THE PRODUCT.

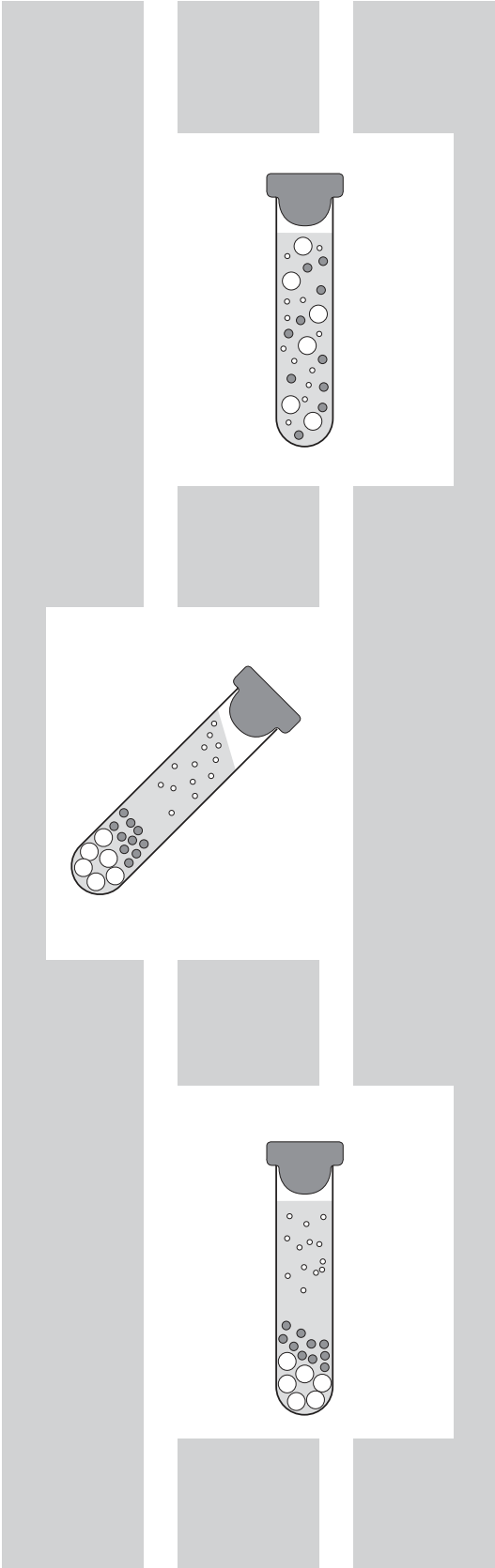

Related Documents

Rotors and Tubes for Beckman Coulter J2, J6, and Avanti J Series Centrifuges

PN JR-IM-10

- Rotors
- Tubes, Bottles, and Accessories
- Using Tubes and Accessories
- Using Fixed-Angle Rotors
- Using Swinging-Bucket Rotors
- Using Vertical-Tube and Rack Type Rotors
- Care and Maintenance
- Chemical Resistances
- Temperature Compensation Tables
- Gradient Materials
- Blood Component Separation

Available in electronic pdf or CD-ROM by request.

Avanti J-26S XP

PN B10087

Avanti J-26S XPI

PN B10093

Avanti J-26 XP

PN J326XP-IM-5

Avanti J-26 XPI

PN J326XPI-IM-4

Avanti J-30I

PN J330I-IM-9

Avanti J-E

PN SJ-IM-8

Avanti JXN

PN B38322

PN B38323

Use and Care of Centrifuge Tubes and Bottles

PN IN-192

Chemical Resistances for Beckman Coulter Centrifugation Products

PN IN-175

High Performance, High Speed, High Capacity Rotors, Tubes, & Accessories

PN BR-1802

Available in hard copy by request.

Available at
www.beckmancoulter.com

www.beckmancoulter.com

